



Range Tribune HE Solar Unvented Direct and Indirect Cylinders

Range Tribune HE Solar cylinders have been designed specifically with Solar applications in mind and are based on the highly successful Range Tribune unvented units. Featuring a purpose designed solar coil which allows maximum heat transfer of solar energy into the stored water, the cylinders are suitable for use with a wide range of solar systems now available in the UK and are an efficient and environmentally friendly way of providing domestic hot water.

Tribune HE Solar cylinders also offer the benefit of mains pressure hot water – powerful showers and fast filling baths. Range Tribune HE Solar cylinders are available in a range of sizes from 180 to 300 litres and in Direct or Indirect versions.

As with the rest of the Range Tribune HE family, Tribune HE Solar cylinders are manufactured from high grade Duplex stainless steel and come with a 25-year fully transferable Guarantee on the inner container.

Technical specifications

DIRECT SOLAR

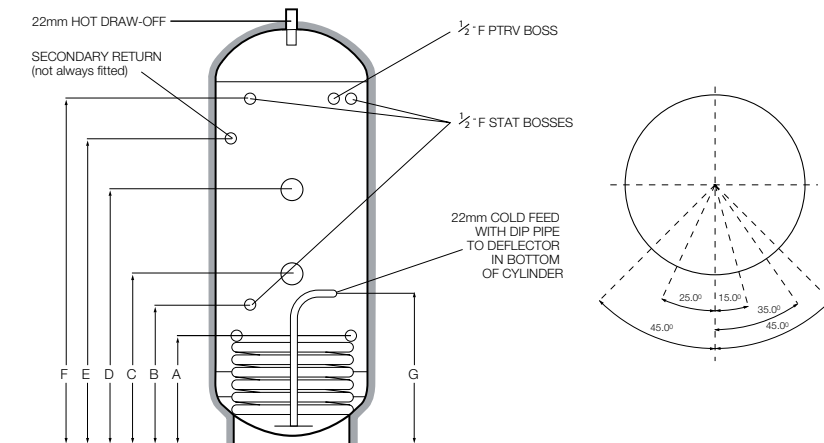

CODE	CAPACITY (Litres)	HEIGHT	DIAMETER	A	B	C	D	E	F	G	WEIGHT (Kg-EMPTY)	WEIGHT (Kg-FULL)
TSS180	180	1281	550	290	345	445	710	N/F	1080	390	45	225
TSS210	210	1469	550	365	420	500	810	1150	1268	465	50	260
TSS250	250	1719	550	365	420	670	1045	1400	1519	465	55	305
TSS300	300	2032	550	365	420	670	1100	1600	1831	465	60	360

N/F = not fitted.

All Dimensions are in mm and are of the cased unit.

Technical specifications

INDIRECT SOLAR

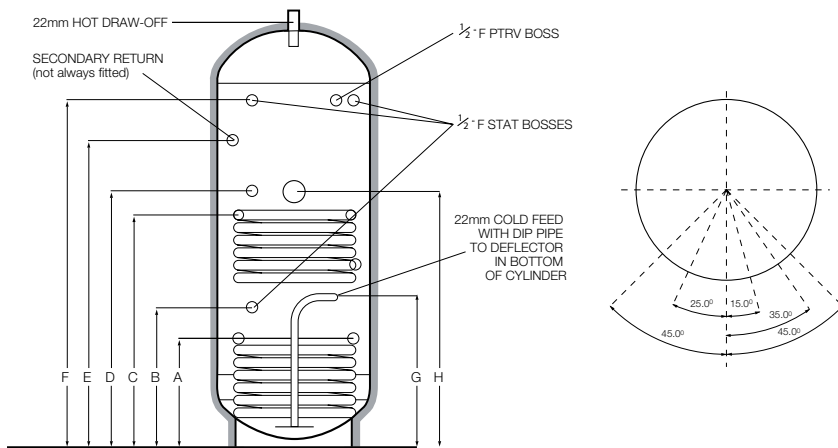

CODE	CAPACITY (Litres)	HEIGHT	DIAMETER	A	B	C	D	E	F	G	H	WEIGHT (Kg-EMPTY)	WEIGHT (Kg-FULL)
TT180	180	1281	550	290	345	674	729	N/F	1080	390	725	50	230
TT210	210	1469	550	365	420	779	834	1150	1268	465	830	55	265
TT250	250	1719	550	365	420	950	1005	1400	1518	465	1000	60	310
TT300	300	2032	550	365	420	979	1034	1600	1832	465	1030	65	365

N/F = not fitted.

All Dimensions are in mm and are of the cased unit.

Range Solar Cylinders are designed to accept heat input from a renewable/sustainable (ie: Solar) heat source.

Where this input does not fully meet the desired temperature, a guaranteed quantity of water can be heated to an acceptable temperature by the householders' traditional heat source of gas, oil or electricity.

The Domestic Heating Compliance Guide document L1A and L1B provides excellent advice in sizing both cylinder designated solar areas and heat exchangers to the surface area of the solar collectors. Using this guide Range are able to offer sizing advice for specification.

Water Capacities (litres)

Model	Designated Solar Area	Fossil Fuel Area	Total Capacity
TT180/TSS180	55	125	180
TT210/TSS210	65	145	210
TT250/TSS250	90	160	250
TT300/TSS300	100	200	300

Lower (Solar) Coil Specification

Model	Surface Area (m ²)	Fluid Content (litres)	
TT180/TSS180	0.670	3.687	
TT210/TSS210	0.878	4.826	
TT250/TSS250	0.878	4.826	NB: The total detail of compliance guide document should be consulted prior to specifying product or commencing design.
TT300/TSS300	0.878	4.826	

Maximum Nett Surface Area of Collector Panel (m²)

As detailed in domestic compliance guide.

Model	Solar Pump Speed	
	< 0.5LPM	> 0.5LPM
TT180/TSS180	3.35	6.70
TT210/TSS210	4.39	8.78
TT250/TSS250	4.39	8.78
TT300/TSS300	4.39	8.78

Foam Insulation and Heat Loss

All stainless unvented HE products utilise the latest foam injection which provides significant improvements in standing heat loss values:

Model (Capacity)	Standing Heat Loss (kWh/24hrs)
90ltr	0.83
120ltr	1.05
150ltr	1.31
180ltr	1.60
210ltr	1.85
250ltr	2.10
300ltr	2.31

In addition our insulation process offers benefits to the 'green' specifier.

Ozone Depletion Potential (ODP) ZERO

Global Warming Potential (GWP) ONE